

RECOMMENDED METAL MASK OPENING PATTERN

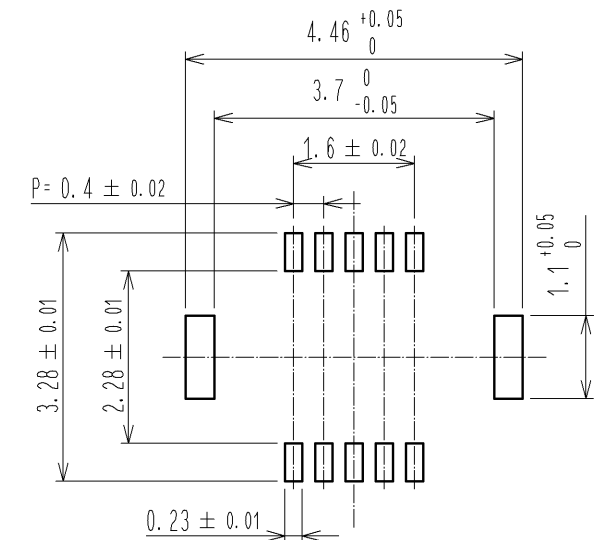

RECOMMENDED PATTERN

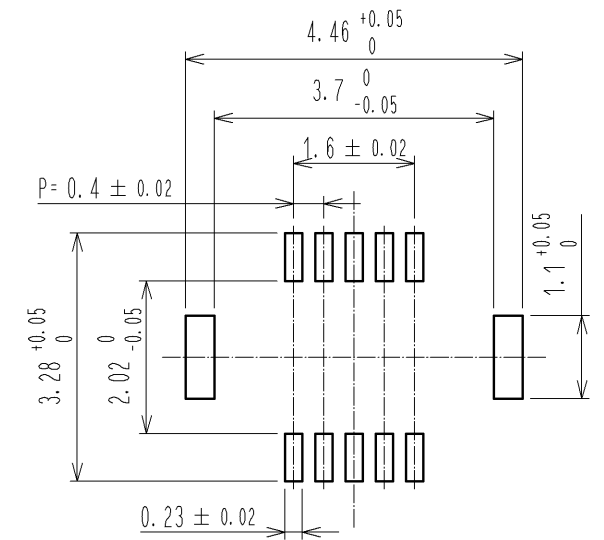

RECOMMENDED SOLDER PASTE THICKNESS: 120µm

A-A (30:1)

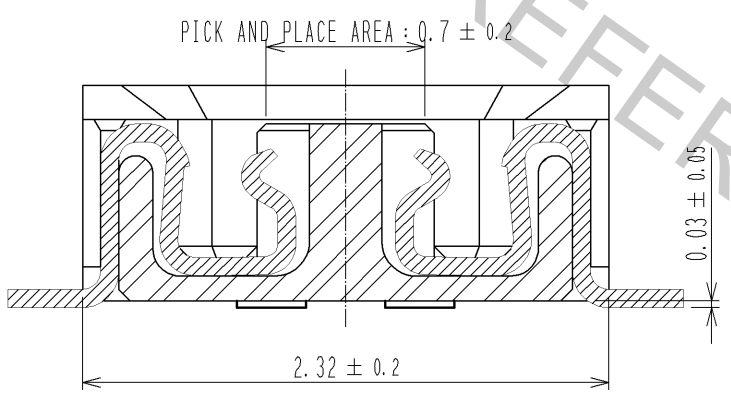

ENGAGEMENT FIGURE (30:1)

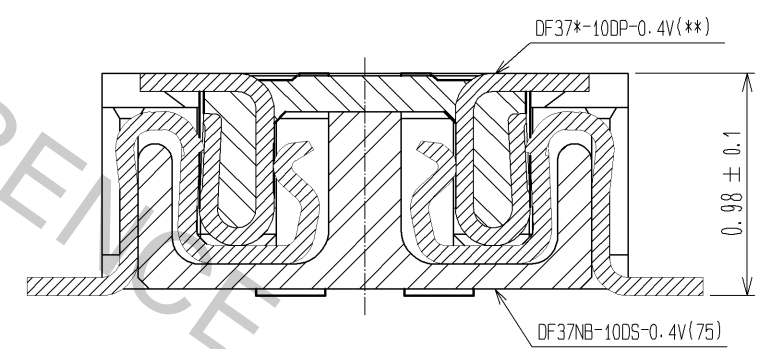

- NOTE 1. ALL LEADS CO-PLANARITY SHALL BE 0.1 MAX.  
 2. PER REEL : 8000 CONNECTORS.  
 3. AT THE BEGINNING OF THE REEL, 100 mm AT MIN SHALL BE EMPTY POCKETS.  
 AT THE END OF THE REEL, 160 mm AT MIN SHALL BE EMPTY.  
 4. CONTACT PLATING SPECIFICATIONS.  
 CONTACT AREA : GOLD 0.1µm MIN.  
 SMT LEAD : GOLD 0.05µm MIN.  
 UNDERPLATING : NICKEL 1µm MIN.  
 (SURFACE : SEALING)  
 5. METAL HOLD DOWN PLATING SPECIFICATIONS.  
 MOUNTING AREA: GOLD 0.05µm MIN.  
 UNDERPLATING : NICKEL 1µm MIN.  
 6. PEEL FORCE OF COVER TAPE REFERS TO JIS C 0806.

3	PHOSPHOR BRONZE	5	6	PS	PLASTIC REEL (BLACK)			
2	PHOSPHOR BRONZE	4	5	POLYESTER	CLEAR(COVER TAPE)			
1	LCP	UL94V-0, BLACK	4	PS	CLEAR(EMBOSSD CARRIER TAPE)			
NO.	MATERIAL	FINISH, REMARKS	NO.	MATERIAL	FINISH, REMARKS			
UNITS	mm	SCALE	FREE	COUNT	DESCRIPTION OF REVISIONS	DESIGNED	CHECKED	DATE
HRS		HIROSE ELECTRIC CO., LTD.	APPROVED : KH. IKEDA	10.11.23	DRAWING NO.	EDC3-319634-06		
			CHECKED : TS. MIYAZAKI	10.11.22	PART NO.	DF37NB-10DS-0.4V(75)		
			DESIGNED : RT. SHIMIZU	10.11.22	CODE NO.	CL684-3301-6-75		
			DRAWN : YN. SAKAMOTO	10.11.19		1/2		

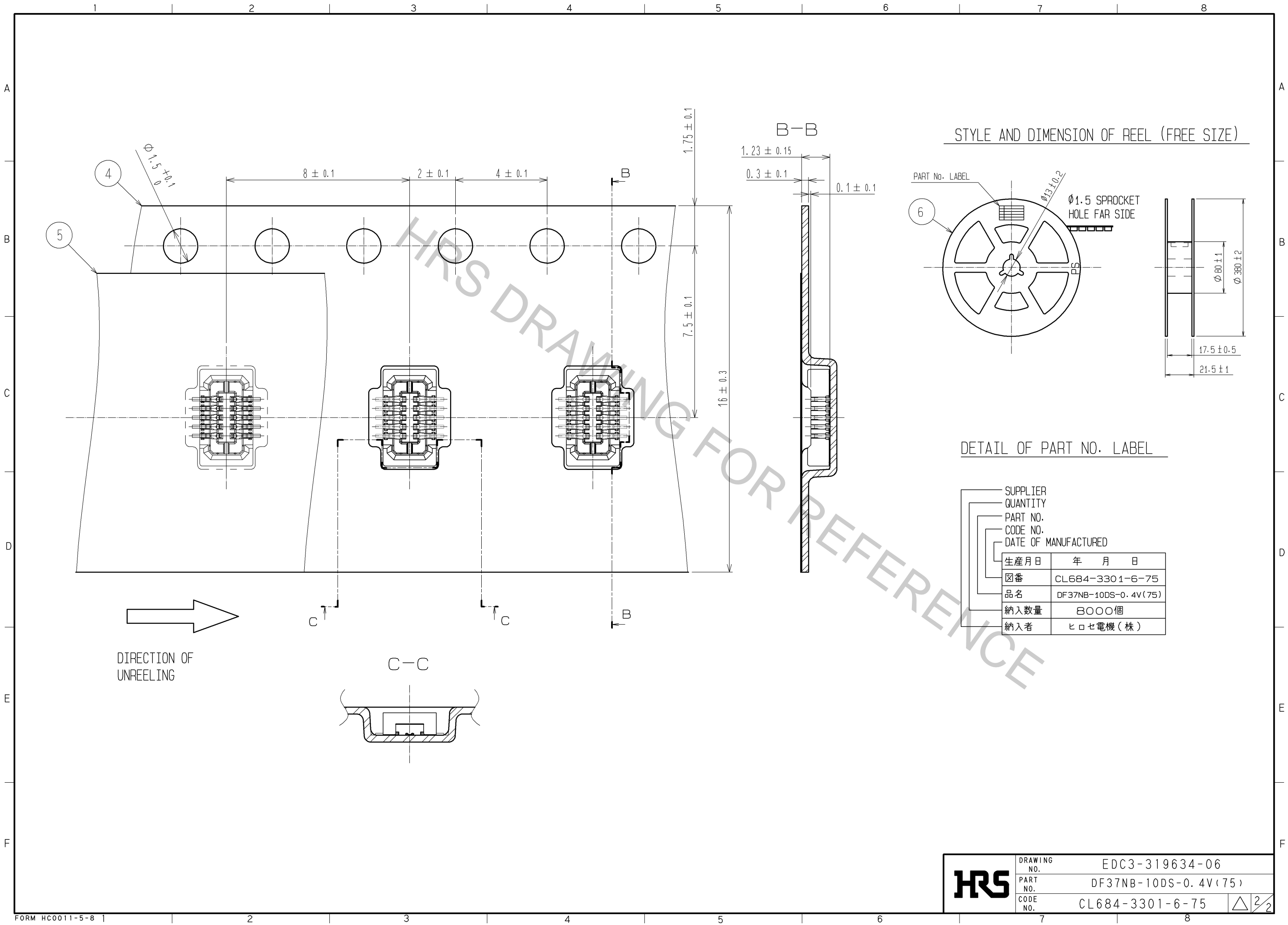

<b>HRS</b>	DRAWING NO.	EDC3-319634-06
	PART NO.	DF37NB-10DS-0.4V(75)
	CODE NO.	CL684-3301-6-75
		△ 2/2